

TrueTouch Thermostat

Residential & Light Commercial Programmable Touch Screen Thermostat

General Description

The TrueTouch residential and light commercial touch screen series of thermostats provide reliable control of up to two (2) stages of cooling and three (3) stages of heating. All of the TrueTouch thermostats provide simple and intuitive touch screen programming for 7 days of scheduling. The TrueTouch thermostats can be configured for either Heat Pump (including Dual Fuel) or Gas/Electric systems. Matching the innovation of the XCI Controls SmartZone products with the simplicity and elegance of the TrueTouch thermostat can provide an energy efficient system without sacrificing comfort.

EASY PROGRAMMING
with TouchScreen Setup

SIMPLE SETUP TouchScreen
Thermostat Configuration

WIRELESS OUTDOOR TEMPERATURE SENSOR
Optional

LED BACKLIT TOUCH SCREEN
Easy to use, easy to see DISPLAY

TrueTouch Thermostat

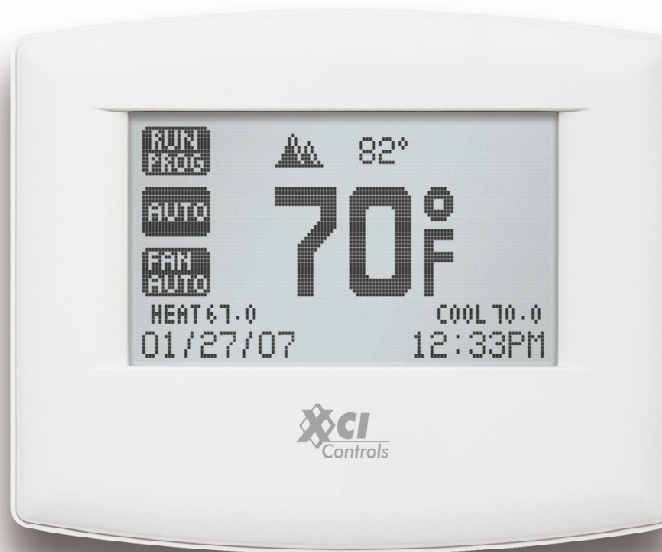

CONTROL EQUIPMENT up to
2-STAGE Cooling
3-STAGE Heating

ENERGY WATCH
monitors HVAC system and provides a total of kwh and cost.

HEAT PUMP or GAS/ELECTRIC
Equipment

SECURITY FEATURE
With password protection for programs and settings

USE XCI SmartZone with TrueTouch Thermostats for effortless EFFICIENCY & COMFORT

Wireless Outdoor Temperature Sensor

■ OPTIONAL



Convenient Features

- Save up to 25% on HVAC energy costs without the loss of comfort
- Dual Fuel Capability ensures maximum efficiency when used with the Wireless Outdoor Temperature Sensor
- StatTrim, the front faceplate of can be painted, wallpapered, or customized in any way to blend seamlessly with any decor
- Automatic Changeover between heating and cooling for Maximum Comfort
- Large, Backlit, Touch Screen Display for easy viewing and operation of all thermostat functions.

SPECIFICATIONS

POWER	TSZ-1	3VA MAX (24V AC or DC)
	EQUIPMENT	4 Amp MAX (Class 2)
	BACKUP	Integrated Electronic Auto-Preserve during power outage
SIZE	DISPLAY	3.625" X 2.125" (95mm X 55mm)
	THERMOSTAT	5.75" X 4.75" X 1.23" (145mm X 120mm X 30mm)

WIRING TABLE

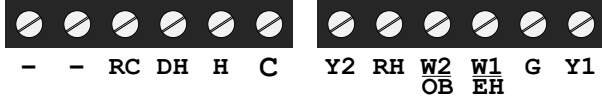

TERMINAL	EQUIPMENT	STANDARD COLOR
Y1	1 st Stage Cooling (Compressor)	Yellow
G	Fan	Green
W1/EH	1 st Stage Heat or Emergency Heat (HP)	White
W2/OB	2 nd Stage Heat or Reversing Valve (HP)	Orange
RH	24VAC Heating	Red
Y2	2 nd Stage Cooling (Compressor)	No Standard
C	24VAC Common	Blue
H	Humidify	No Standard
DH	De-Humidify	No Standard
RC	24VAC Cooling	Red

Part Numbers

- **TSZ-1**
TrueTouch Thermostat – 1 Stage Cool, 2 Stage Heat
- **TSZ-2**
TrueTouch Thermostat – 2 Stage Cool, 3 Stage Heat
- **TSH-2**
TrueTouch Thermostat – 2 Stage Cool, 3 Stage Heat, Humidity Control
- **TOS**
Wireless Outdoor Temperature Transmitter Kit
- **SZ2-KIT**
SmartZone-2 (2-Zone) Kit including 2 thermostats, static pressure controller, and 24VAC transformer
- **SZ3-KIT**
SmartZone-4 (3-Zone) Kit including 3 thermostats, static pressure controller, and 24VAC transformer
- **SZ4-KIT**
SmartZone-4 (4-Zone) Kit including 4 thermostats, static pressure controller, and 24VAC transformer

Other References

- **TrueTouch Manual** for a full guide to this product
- **SmartZone-PLUS Quick-Reference Sheet** for a brief overview of Zoning large systems
- **SmartZone-2&4 Quick-Reference Sheet** for a brief overview of Zoning small systems
- References available at xcicontrols.com or by calling toll free 866-924-4822

XCI SmartZone Product Line

SmartZone-2, SmartZone-4, SmartZonePLUS

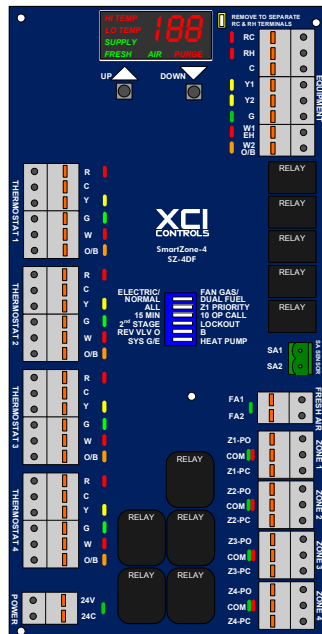

SmartZone Dampers

